

Madison County, Mississippi

Gated Public Streets Policy

Definitions:

Public Street - A public vehicular access way (street) shared by and serving two or more lots, which is dedicated to the public and is publicly maintained.

Gates controlling entry to residential subdivisions on public streets shall meet the following requirements:

1. The street must be fully and equally accessible to the public, by reasonable and obvious means. No plan will be approved which is designed, marked with signs or otherwise laid out so as to give an impression that the street is a private one. At a minimum, this would mean a clearly visible sign identifying the access mechanism.
2. Any request should include specific plans and specifications for the gate. The Board will not be in a position to authorize the gate unless County personnel have had an opportunity to review all technical and design aspects of the proposed gate. Specific requirements include:
 - a. A design professional, preferably a registered Landscape Architect, shall design every element of the gated entry, including gate design, location, pedestrian access, lighting, planting, signage, etc. and present the design to the Planning & Zoning Administrator for preliminary review and subsequent review by other County personnel as needed.
 - b. Specific elements of the design include:
 - i. The entry gate will be designed in such way as to avoid any damage to any public infrastructure including road surface, base, and curbing.
 - ii. All gates will be required to open away from, not toward, a vehicle.
 - iii. A “BE PREPARED TO STOP” caution sign (*plate 1*) shall be installed at least 100 feet before the gate on both the entry and exit side. If one hundred feet is not feasible the sign shall be located the discretion of the County Engineer. The sign shall be 36 inches square for installations where the traffic speed is 30 miles per hour or greater and 30" square for installations on roadways less than 30 miles per hour consistent with the current edition of the Manual of Uniform Traffic Control Devices Handbook (MUTCD). The sign shall be supported on a post meeting county specifications.
 - iv. A “PULL HERE FOR ENTRY” and “PULL HERE FOR EXIT” sign (*plate 2*) shall be installed prior to the gate where the access control mechanism is installed along with a 12" min. width white painted line to indicate the appropriate stopping point. *As stated above it should be obvious that anyone can enter the subdivision.*
 - v. Emergency access will consist, at minimum, of a siren operated system and a Fire Box.
 - vi. A walk-through gate will be provided to allow pedestrian access, constructed to connect to street or existing sidewalks.
 - vii. Gate equipment will be either pre-finished in an approved color or painted

- with an approved color and screened with plant material as required.
- viii. Lighting - The gate will be lighted sufficiently to be easily seen at night without any added external light source, i.e. from a car or bicycle headlights and will include an element of reflectivity.
3. The parties requesting the gate should be prepared to assume all costs and responsibility for installation and maintenance of the gate, including repair or replacement costs if anything happens to the gate for any reason, including accident, vandalism or simple mechanical failure.
 4. The County must have the right to remove the gate at any time for any reason or for no reason whatsoever, although we could make arrangements to return the mechanism to parties who installed the gate, if feasible. If the gate is removed for any reason except safety issues, street or utility construction, reconstruction or relocation, or failure of the sponsoring party to comply with any of the policies established herein, the County will reimburse the sponsoring party for the original cost of the gate, or any portion which is removed.
 5. Any request for a gate must be submitted by the Home Owners Association, or, if an association does not exist, by 75% of the property owners fronting the public streets directly affected by the request.
 6. The parties requesting the gate shall sign an agreement (*Exhibit I*) to indemnify and hold harmless the County from any and all costs and expenses associated with defending any claims associated in any way with the approval of such request and the installation and maintenance of the gate. The County will require proof of insurance or other evidence of ability to provide indemnification and the county will be listed as co-insured.

General Information

1. Any approval should be based upon a finding by the Board that approval of the request is necessary to preserve the good order and peace of the County or to prevent injury to public or private property.
2. All signage, posts, etc., to be paid for by the HOA or other responsible parties and installed by the Homeowners Association or the Developer.
3. This policy applies only to gated public streets, *whether or not they are planned to be open for the majority of the day*. Private streets are subject to separate application and evaluation.
4. All gate installations are to be reviewed and approved by the County prior to making the gates functional.
5. Damaged signs are to be replaced by the Home Owners Association or other responsible parties.

Adopted By:
Madison County, Mississippi
Board of Supervisors
October 17, 2011



Plate 1



Plate 2

[DATE]

Madison County, Mississippi
Post Office Box 608
Canton, Mississippi 39046

Dear Board:

As part of the request of the undersigned party to install a traffic control gate on a public street, we hereby acknowledge the receipt of and agree to abide by the terms of the County's "Policy Regarding Gated Public Streets."

We specifically agree to indemnify and hold harmless the County from any and all costs associated with defending any claims associated in any way with the approval of this request and the installation and maintenance of the gate or gates.

We understand and agree that before any gate or gates are installed, we will furnish proof of insurance, in a form acceptable to the County, in an amount not less than \$1,000,000.00, with the County named as a named insured.

We understand that any failure to abide by the terms of this agreement, or any terms of the County's policy identified above, may result in removal of the gate with no compensation or damages of any type paid to us. We further acknowledge that the gate may be removed at any time in accordance with the provisions of the policy.

[Applicant]

Accepted by:

On behalf of Madison County, Mississippi

Exhibit 1

May 20, 2019

Madison County, Mississippi
Post Office Box 608
Canton, Mississippi 39046

Dear Board:

As part of the request of the undersigned party to install a traffic control gate on a public street, we hereby acknowledge the receipt of and agree to abide by the terms of the County's "Policy Regarding Gated Public Streets."

We specifically agree to indemnify and hold harmless the County from any and all costs associated with defending any claims associated in any way with the approval of this request and the installation and maintenance of the gate or gates.

We understand and agree that before any gate or gates are installed, we will furnish proof of Insurance, in a form acceptable to the County, in an amount not less than \$1,000,000.00, with the County named as a named insured.

We understand that any failure to abide by the terms of this agreement, or any terms of the County's policy identified above, may result in removal of the gate with no compensation or damages of any type paid to us. We further acknowledge that the gate may be removed at any time in accordance with the provisions of the policy.

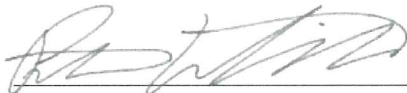

Peter Whitman
President, Providence Property Owners Association

Accepted by:

On behalf of Madison County, Mississippi



PROVI-1

OP ID: VA

CERTIFICATE OF LIABILITY INSURANCE

DATE (MM/DD/YYYY)

05/21/2019

THIS CERTIFICATE IS ISSUED AS A MATTER OF INFORMATION ONLY AND CONFERS NO RIGHTS UPON THE CERTIFICATE HOLDER. THIS CERTIFICATE DOES NOT AFFIRMATIVELY OR NEGATIVELY AMEND, EXTEND OR ALTER THE COVERAGE AFFORDED BY THE POLICIES BELOW. THIS CERTIFICATE OF INSURANCE DOES NOT CONSTITUTE A CONTRACT BETWEEN THE ISSUING INSURER(S), AUTHORIZED REPRESENTATIVE OR PRODUCER, AND THE CERTIFICATE HOLDER.

IMPORTANT: If the certificate holder is an ADDITIONAL INSURED, the policy(ies) must have ADDITIONAL INSURED provisions or be endorsed. If SUBROGATION IS WAIVED, subject to the terms and conditions of the policy, certain policies may require an endorsement. A statement on this certificate does not confer rights to the certificate holder in lieu of such endorsement(s).

PRODUCER The Clark Group Ins, Inc(AS). Adam Smith - GM 624 Ridgewood Road, SUITE B Ridgeland, MS 39157 Adam Smith - Trusted Advisor	CONTACT NAME: Vanessa Ashley PHONE (A/C, No, Ext): 601-213-4223 FAX (A/C, No): 601-213-4201 E-MAIL ADDRESS: vashley@tcg-insurance.net
INSURER(S) AFFORDING COVERAGE	
INSURER A : NW Property & Casualty Ins Co.	NAIC # 37877
INSURER B : NW Mutual Fire Insurance Co.	23779
INSURER C : Bloomington Compensation Ins C	
INSURER D :	
INSURER E :	
INSURER F :	

INSURED
 Providence Property Owners
 Association
 P.O. Box 1305
 Ridgeland, MS 39158

COVERAGES**CERTIFICATE NUMBER:****REVISION NUMBER:**

THIS IS TO CERTIFY THAT THE POLICIES OF INSURANCE LISTED BELOW HAVE BEEN ISSUED TO THE INSURED NAMED ABOVE FOR THE POLICY PERIOD INDICATED. NOTWITHSTANDING ANY REQUIREMENT, TERM OR CONDITION OF ANY CONTRACT OR OTHER DOCUMENT WITH RESPECT TO WHICH THIS CERTIFICATE MAY BE ISSUED OR MAY PERTAIN, THE INSURANCE AFFORDED BY THE POLICIES DESCRIBED HEREIN IS SUBJECT TO ALL THE TERMS, EXCLUSIONS AND CONDITIONS OF SUCH POLICIES. LIMITS SHOWN MAY HAVE BEEN REDUCED BY PAID CLAIMS.

INSR LTR	TYPE OF INSURANCE	ADDL INSD	SUBR WVD	POLICY NUMBER	POLICY EFF (MM/DD/YYYY)	POLICY EXP (MM/DD/YYYY)	LIMITS
A	COMMERCIAL GENERAL LIABILITY	X		ACPBPHK5684468297	07/24/2018	07/24/2019	EACH OCCURRENCE \$ 1,000,000
	<input type="checkbox"/> CLAIMS-MADE <input type="checkbox"/> OCCUR						DAMAGE TO RENTED PREMISES (Ea occurrence) \$ 300,000
	<input checked="" type="checkbox"/> Business Owners						MED EXP (Any one person) \$ 5,000
	GEN'L AGGREGATE LIMIT APPLIES PER: <input type="checkbox"/> POLICY <input type="checkbox"/> PRO-JECT <input type="checkbox"/> LOC						PERSONAL & ADV INJURY \$ 1,000,000
	OTHER:						GENERAL AGGREGATE \$ 2,000,000
							PRODUCTS - COMP/OP AGG \$ 2,000,000
							\$
	AUTOMOBILE LIABILITY						COMBINED SINGLE LIMIT (Ea accident) \$
	<input type="checkbox"/> ANY AUTO OWNED AUTOS ONLY <input type="checkbox"/> SCHEDULED AUTOS						BODILY INJURY (Per person) \$
	<input type="checkbox"/> HIRED AUTOS ONLY <input type="checkbox"/> NON-OWNED AUTOS ONLY						BODILY INJURY (Per accident) \$
							PROPERTY DAMAGE (Per accident) \$
							\$
B	<input checked="" type="checkbox"/> UMBRELLA LIAB <input checked="" type="checkbox"/> OCCUR			ACPCAF5684468297	08/27/2018	08/27/2019	EACH OCCURRENCE \$ 1,000,000
	<input type="checkbox"/> EXCESS LIAB <input type="checkbox"/> CLAIMS-MADE						AGGREGATE \$ 1,000,000
	DED RETENTION \$						\$
C	WORKERS COMPENSATION AND EMPLOYERS' LIABILITY			BC-MS-000018-5	01/14/2019	01/14/2020	<input checked="" type="checkbox"/> PER STATUTE <input type="checkbox"/> OTH-ER
	ANY PROPRIETOR/PARTNER/EXECUTIVE OFFICER/MEMBER EXCLUDED? (Mandatory in NH)	Y / N	N / A				E.L. EACH ACCIDENT \$ 100,000
	If yes, describe under DESCRIPTION OF OPERATIONS below						E.L. DISEASE - EA EMPLOYEE \$ 100,000
							E.L. DISEASE - POLICY LIMIT \$ 500,000

DESCRIPTION OF OPERATIONS / LOCATIONS / VEHICLES (ACORD 101, Additional Remarks Schedule, may be attached if more space is required)

The Certificate Holder is Named as Additional Insured as Respects the General Liability, as Required by Written Contract.

CERTIFICATE HOLDER**CANCELLATION**

Madison County, Mississippi
 PO Box 608
 Canton, MS 39046

SHOULD ANY OF THE ABOVE DESCRIBED POLICIES BE CANCELLED BEFORE THE EXPIRATION DATE THEREOF, NOTICE WILL BE DELIVERED IN ACCORDANCE WITH THE POLICY PROVISIONS.

AUTHORIZED REPRESENTATIVE

Entrance and Exit Gates:

- (1) Two 18 foot single swing gates per drawing
 - a. 3 inch x 2 inch x 3/16" swing vertical for hinges
 - b. 3 inch x 2 inch x 11 gauge other frame
 - c. 3/4 inch pickets
 - d. Four 6" x 6" x .250" swing post with pyramid caps
 - e. 8" ball bearing hinges with grease fittings
 - f. All primed and powder coated Statuary Bronze
 - g. Safety signs installed on gates
 - h. Gates and installation and fabrication to comply with UL-325-2018 and ASTM F2200 safety codes
- (2) Gate automation
 - a. Two Max Megatron 2200 Pro low profile gate operators
 - b. Battery backup (required by Madison County)
 - c. Electrical to gate operators by Iron Innovations
 - d. Two operator mounts
 - e. Two high voltage surge protectors
 - f. Two ground rods
 - g. Two ground clamps
 - h. One radio receivers (for remote operation of entry
 - i. One antenna
 - j. One two button radio transmitter (additional - \$33.00 each)
- (3) Safety
 - a. Six safety loops saw cut in asphalt with free entry and exit
 - b. Six loop detectors
 - c. Two photo eyes with hoods across opening for UL-325-2016 safety code
 - d. One fire box for emergency access
 - e. One Siren Operated Sensor for emergency access
 - f. Access
 - a. One sign "STOP HERE FOR EXIT"
 - b. One sign "STOP HERE FOR ENTRY"
 - c. Two signs and post "BE PREPARED TO STOP" (required by Madison County)
 - d. White lines on pavement to depict where to stop
 - e. 7-Day timer for "Hold Open" feature

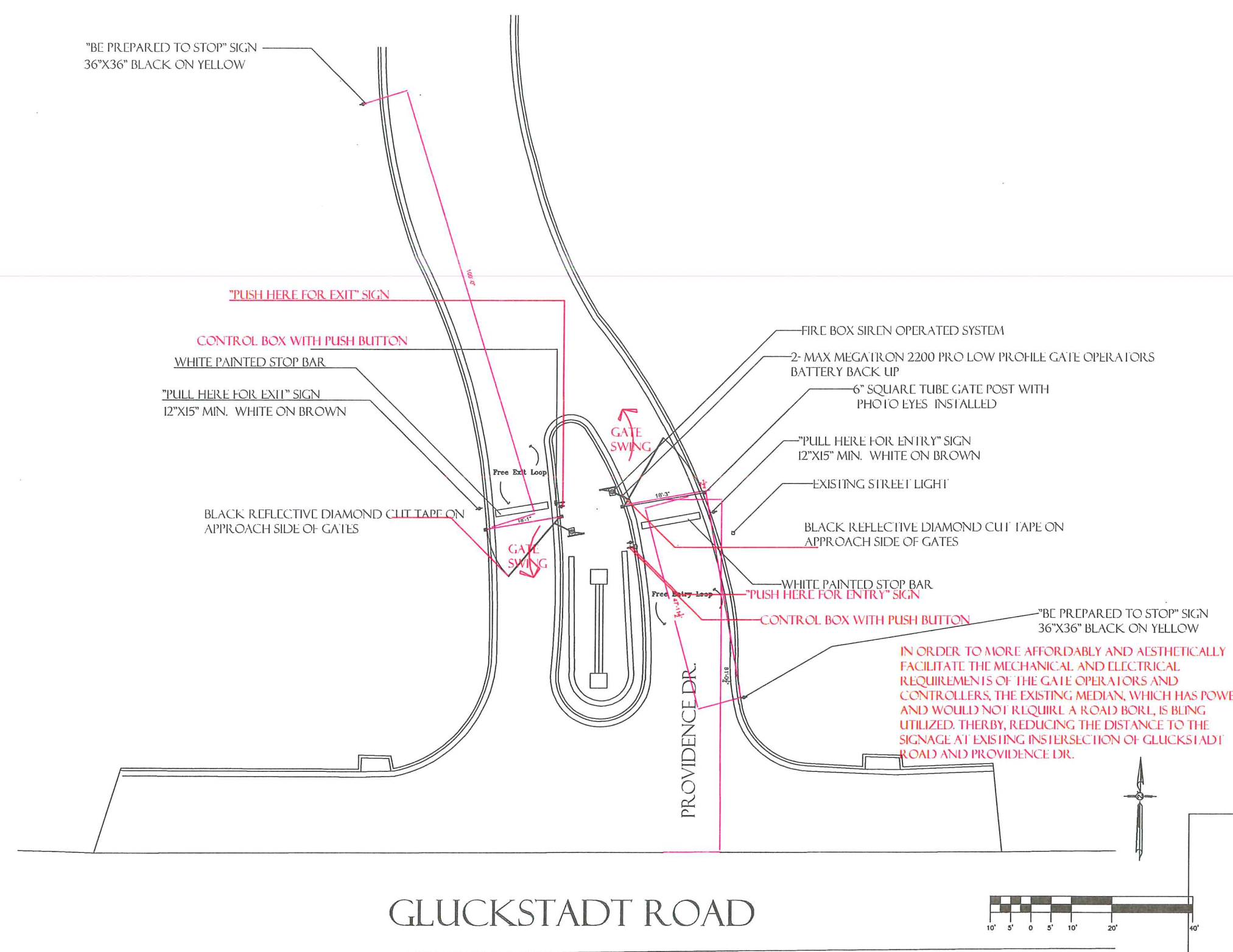

PPLS
 TERRY POWELL
 LANDSCAPE ARCHITECT
 137 Ashdon Park Boulevard
 Madison, MS 39110
 601-652-9048
 TPOWELL@comcast.net

REVISIONS

NO.	DATE	ISSUE

Providence Subdivision
 Entrance

TITLE: _____

DATE: 6/17/19

JOB NO.: _____

DRAWN BY: TRP

CHECKED: _____

SHEET: _____

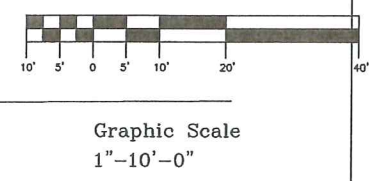

IN ORDER TO MORE AFFORDABLY AND AESTHETICALLY FACILITATE THE MECHANICAL AND ELECTRICAL REQUIREMENTS OF THE GATE OPERATORS AND CONTROLLERS, THE EXISTING MEDIAN, WHICH HAS POWER, AND WOULD NOT REQUIRE A ROAD BOWL, IS BEING UTILIZED. THEREBY, REDUCING THE DISTANCE TO THE SIGNAGE AT EXISTING INTERSECTION OF GLUCKSTADT ROAD AND PROVIDENCE DR.

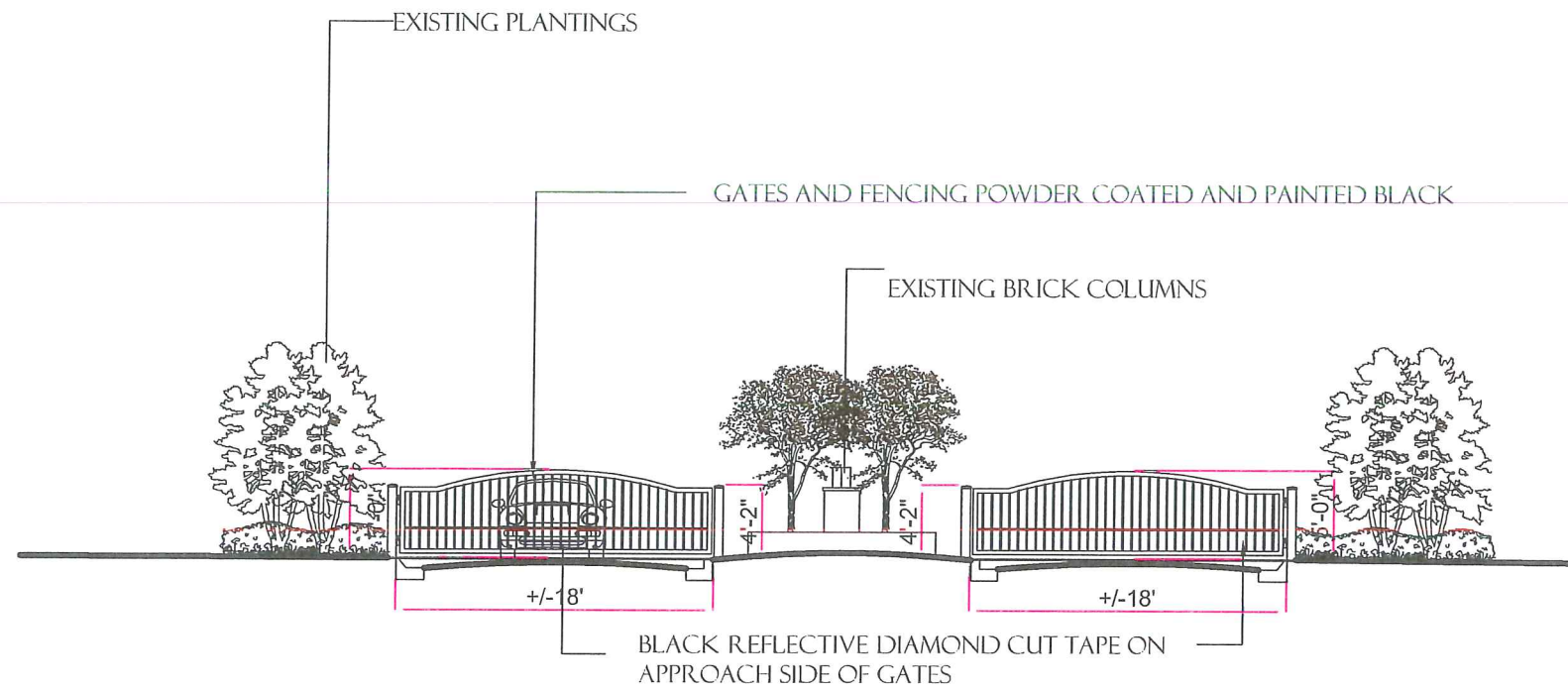

FRONT ELEVATION

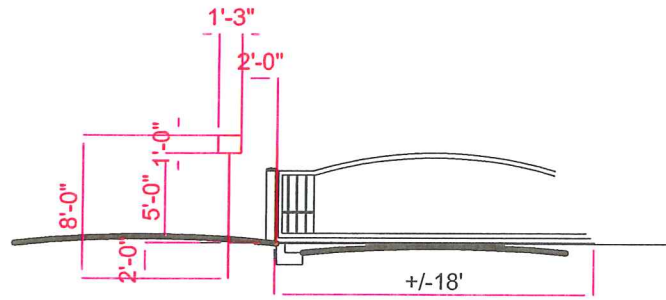

TYPICAL SIGN CLEARANCE

NOTE:
 ALL SIGNS TO BE INSTALED BY PERMITEE, NOT COUNTY
 ALL SIGNS TO BE HIGH INTENSITY SHEETING ON 0.125" BLANKS
 ALL SIGN POSTS TO MATCH THE EXISTING DECORATIVE SIGN POST IN PROVIDENCE

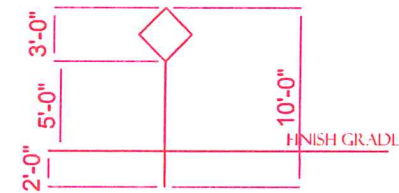

PPLS

TERRY POWELL
 LANDSCAPE ARCHITECT
 127 Ashton Park Boulevard
 Madison, MS 39110
 601-652-5016
 TPOWELL@comcast.net

Powell Place Landscape Services, Inc.

REVISIONS

NO.	DATE	ISSUE

Providence Subdivision
 Entrance

TITLE:

DATE: 5/17/10

JOB NO.:

DRAWN BY: TRP

CHECKED:

SHEET:

